

Twin-Pack CAST STEEL FLANGED ENDS GATE VALVES

■ 150LB (10K)

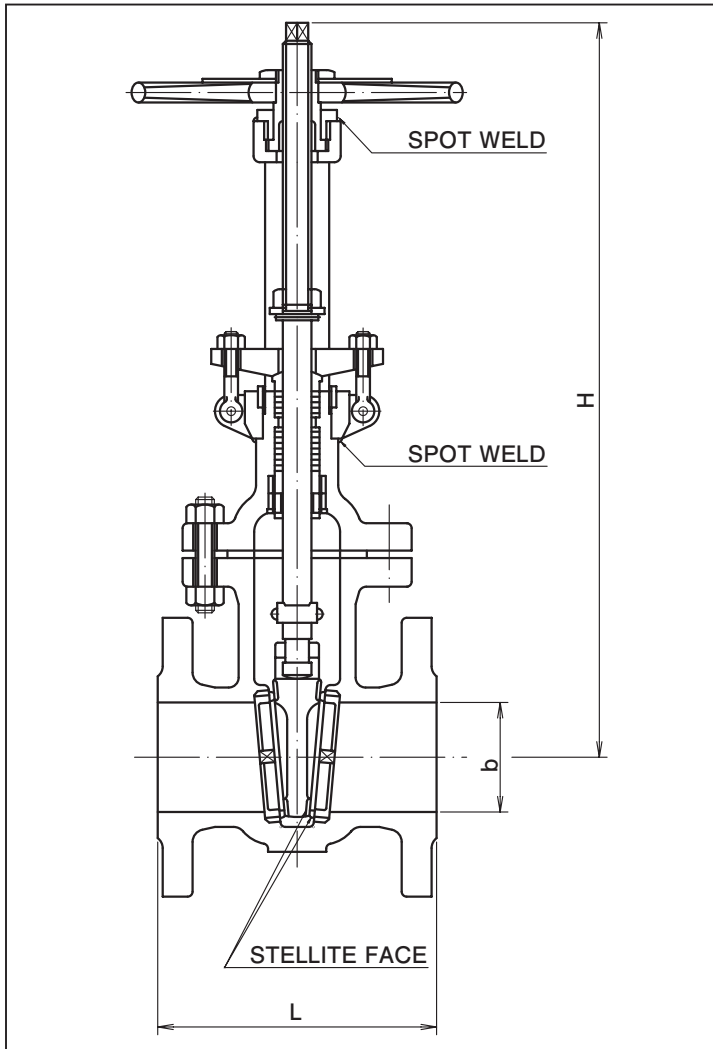

MATERIAL

No.	NAME OF PART	MATERIALS	
		JIS	ASTM
1	BODY	SCPH2	A216-WCB
2	BODY SEAT RING	S25C	CARBON STEEL
3	DISC	S25C	CARBON STEEL
4	STEM	SUS403	13%Cr S.S
5	GASKET		
6	BONNET	SCPH2	A216-WCB
7	BONNET BOLT	SNB7	A193-B7
8	NUT	S45C	A194-2H
9	BONNET BUSH	SUS420J2	13%Cr S.S
10	GLAND PACKING		
11	GLAND	SUS420J2	13%Cr S.S
12	GLAND FLANGE	S25C	CARBON STEEL
13	GLAND EYE BOLT	S25C	CARBON STEEL
14	NUT	S20C	CARBON STEEL
15	YOKE SLEEVE	NiBC	Ni-Cu ALLOY
16	SLEEVE RETAINING NUT	S25C	CARBON STEEL
17	HAND WHEEL	FCD45	DUCTILE IRON
18	LOCK NUT	SS41	CARBON STEEL
19	NAME PLATE	AL. P	ALUMINIUM
20	SET SCREW	SUS304	304 S.S
21	YOKE	SCPH2	A216-WCB
22	YOKE RETAINING NUT	S25C	CARBON STEEL
23	PACKING WASHER	SUS420J2	13%Cr S.S
24	PACKING WASHER	SUS420J2	13%Cr S.S
25	CLUTCH	SUS420J2	13%Cr S.S
26	KNOCK PIN	SUS304	304 S.S
27	STOPPER	SS41	CARBON STEEL
28	KNOCK PIN	SUS304	304 S.S
29	LOCK NUT	SS41	CARBON STEEL
30	BALL-BEARING		

WEIGHT AND DIMENSIONS

SIZE	DIMENSIONS mm			NET WEIGHTS kg		SIZE	DIMENSIONS mm			NET WEIGHTS kg	
	b	L	H	150lb	10K		b	L	H	150lb	10K
2"	51	178	552	23.5	23.7	8"	203	292	1280	135.0	132.0
2 1/2"	64	190	630	27.0	26.8	10"	254	330	1538	208.0	206.0
3"	76	203	673	33.0	32.5	12"	305	356	1755	285.0	271.0
4"	102	229	777	49.0	46.5	14"	337	381	1876	385.0	366.0
6"	152	267	1049	90.0	90.2	16"	387	406	2091	505.0	486.0