

Twin-Pack CAST STEEL FLANGED ENDS GLOBE VALVES

■150LB (10K)

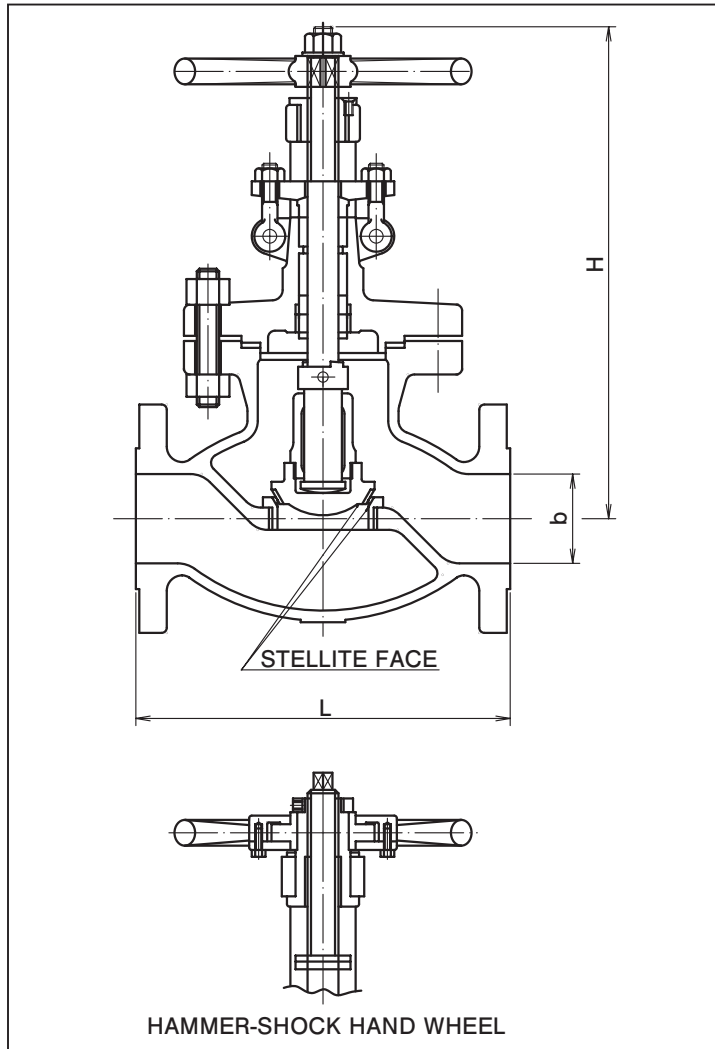

MATERIAL

No.	NAME OF PART	MATERIALS	
		JIS	ASTM
1	BODY	SCPH2	A216-WCB
2	BODY SEAT RING	S25C	CARBON STEEL
3	DISC	S25C	CARBON STEEL
4	DISC NUT	SUS403	13%Cr S.S
5	STEM	SUS403	13%Cr S.S
6	BONNET	SCPH2	A216-WCB
7	BONNET BOLT	SNB7	A193-B7
8	NUT	S45C	A194-2H
9	GASKET		
10	BONNET BUSH	SUS420J2	13%Cr S.S
11	PACKING WASHER	SUS420J2	13%Cr S.S
12	PACKING WASHER	SUS420J2	13%Cr S.S
13	GLAND PACKING		
14	GLAND	SUS420J2	13%Cr S.S
15	GLAND FLANGE	S25C	CARBON STEEL
16	EYE BOLT	S25C	CARBON STEEL
17	NUT	S20C	CARBON STEEL
18	PIN	SUS403	13%Cr S.S
19	WASHER	SS41	CARBON STEEL
20	SPLIT PIN	SWRM3	CARBON STEEL
21	YOKE BUSH	NIBC	Ni-Cu ALLOY
22	SET SCREW	SUS304	304 S.S
23	HAND WHEEL	FCD45	DUCTILE IRON
24	WASHER	SS41	CARBON STEEL
25	LOCK NUT	SS41	CARBON STEEL
26	NAME PLATE	AL P	ALUMINIUM
27	CLUTCH	SUS420J2	13%Cr S.S
28	KNOCK PIN	SUS304	304 S.S

WEIGHT AND DIMENSIONS

SIZE	DIMENSIONS mm			NET WEIGHTS kg		SIZE	DIMENSIONS mm			NET WEIGHTS kg	
	b	L	H	150lb	10K		b	L	H	150lb	10K
2"	51	203	400	27.0	27.2	6"	152	406	598	115.0	115.2
2 1/2"	64	216	425	36.0	35.8	8"	203	495	719	200.0	197.0
3"	76	241	455	41.0	40.5	10"	254	622	1040	315.0	313.0
4"	102	292	509	65.0	62.5	12"	305	698	1201	495.0	481.0