

Twin-Pack CAST STEEL FLANGED ENDS GLOBE VALVES

■ 300LB (20K)

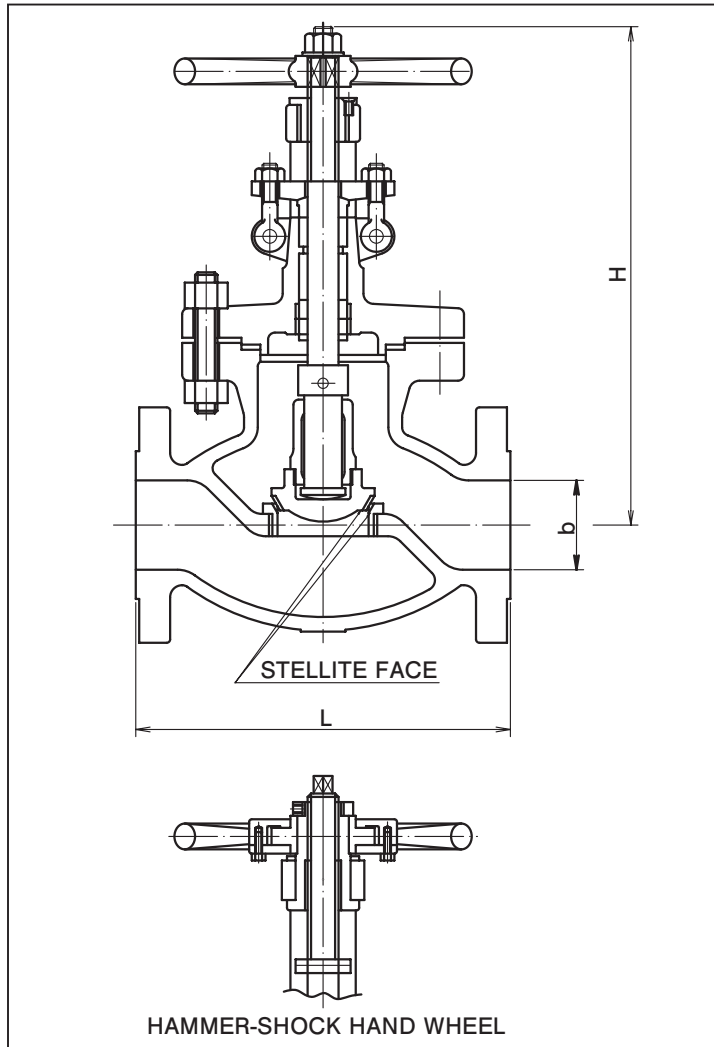

MATERIAL

No.	NAME OF PART	MATERIALS	
		JIS	ASTM
1	BODY	SCPH2	A216-WCB
2	BODY SEAT RING	S25C	CARBON STEEL
3	DISC	S25C	CARBON STEEL
4	DISC NUT	SUS403	13%Cr S.S
5	STEM	SUS403	13%Cr S.S
6	BONNET	SCPH2	A216-WCB
7	BONNET BOLT	SNB7	A193-B7
8	NUT	S45C	A194-2H
9	GASKET		
10	BONNET BUSH	SUS420J2	13%Cr S.S
11	PACKING WASHER	SUS420J2	13%Cr S.S
12	PACKING WASHER	SUS420J2	13%Cr S.S
13	GLAND PACKING		
14	GLAND	SUS420J2	13%Cr S.S
15	GLAND FLANGE	S25C	CARBON STEEL
16	EYE BOLT	S25C	CARBON STEEL
17	NUT	S20C	CARBON STEEL
18	PIN	SUS403	13%Cr S.S
19	WASHER	SS41	CARBON STEEL
20	SPLIN PIN	SWRM3	CARBON STEEL
21	YOKE BUSH	NIBC	Ni-Cu ALLOY
22	SET SCREW	SUS304	304S.S
23	HAND WHEEL	FCD45	DUCTILE IRON
24	WASHER	SS41	CARBON STEEL
25	LOCK NUT	SS41	CARBON STEEL
26	NAME PLATE	AL. P	ALUMINIUM
27	CLUTCH	SUS420J2	13%Cr S.S
28	KNOCK PIN	SUS304	304S.S

WEIGHT AND DIMENSIONS

SIZE	DIMENSIONS mm			NET WEIGHTS kg		SIZE	DIMENSIONS mm			NET WEIGHTS kg	
	b	L	H	300lb	20K		b	L	H	300lb	20K
1 1/2"	38	229	376	29.0	28.5	6"	152	444	717	208.0	205.0
2"	51	267	397	36.0	35.0	8"	203	559	812	330.0	319.0
2 1/2"	64	292	438	59.0	58.0	10"	254	622	1015	495.0	488.0
3"	76	318	464	70.0	69.0	12"	305	711	1100	710.0	685.0
4"	102	356	565	103.0	98.0						