

CAST STEEL GATE VALVES

ASME CLASS 150

SIZE 2" to 48"  
 Flanged and Butt weld Ends  
 Bolted Bonnet, O.S. & Y.  
 R.F. End Type. Fig. No. C2240  
 B.W. End Type. Fig. No. C2230

INDEX

CLASS	FIG.NO.	TYPE	END CONNECTION	PAGE
150	C2240 C2230	GATE VALVE	RF FLANGED BUTT WELD	3
300	C2440 C2470 C2430	GATE VALVE	RF FLANGED RJ FLANGED BUTT WELD	4
600	C2640 C2670 C2630	GATE VALVE	RF FLANGED RJ FLANGED BUTT WELD	5
150	C1240 C1230	GLOBE VALVE	RF FLANGED BUTT WELD	6
300	C1440 C1470 C1430	GLOBE VALVE	RF FLANGED RJ FLANGED BUTT WELD	7
600	C1640 C1670 C1630	GLOBE VALVE	RF FLANGED RJ FLANGED BUTT WELD	8
150	C4240 C4230	SWING CHECK VALVE	RF FLANGED BUTT WELD	9
300	C4440 C4470 C4430	SWING CHECK VALVE	RF FLANGED RJ FLANGED BUTT WELD	10
600	C4640 C4670 C4630	SWING CHECK VALVE	RF FLANGED RJ FLANGED BUTT WELD	11

FIGURE NUMBERS

BODY/BONNET MATERIAL	←	FIG. C-2240-H	→	TRIM
C — ASTM A216 WCB				H — HALF STELLITE
F — ASTM A217 WC1				B — FULL STELLITE
H — ASTM A217 WC6				C — 304 SS
I — ASTM A217 C5				C1 — 316 SS
S — ASTM A352 LCB				M — MONEL
W — ASTM A352 LC3				

PRESSURE TEST: As per API 598

MATERIAL

NAME OF PART	ASTM	JIS
BODY	A216 WCB	SCPH2
BODY SEAT RING	* A105	* SFVC2A
DISC	* A216 WCB	* SCPH2
STEM	A182 F6a	SUS403
BONNET GASKET	REIN FORCED GRAPHITE	
BONNET	A216 WCB	SCPH2
BONNET BOLT	A193 B7	SNB7
BONNET BOLT NUT	A194 2H	S45C
BONNET BUSH	A276 420	SUS420J2
GLAND PACKING	FLEXIBLE GRAPHITE	
GLAND	A276 420	SUS420J2
GLAND FLANGE	A105	SFVC2A
GLAND EYE BOLT	A193 B7	SNB7
GL. EYE BOLT NUT	A194 2H	S45C
YOKE	A216 WCB	SCPH2
YOKE SLEEVE	A439 D2	FCDA NiCr
SLEEVE NUT	A576 1025	S25C
HAND WHEEL	A536	FCD450
LOCK NUT	A36	SS400
NAME PLATE	B209M	ALP

\* BODY SEAT RING: STELLITE FACE  
 \* DISC: 13Cr FACE

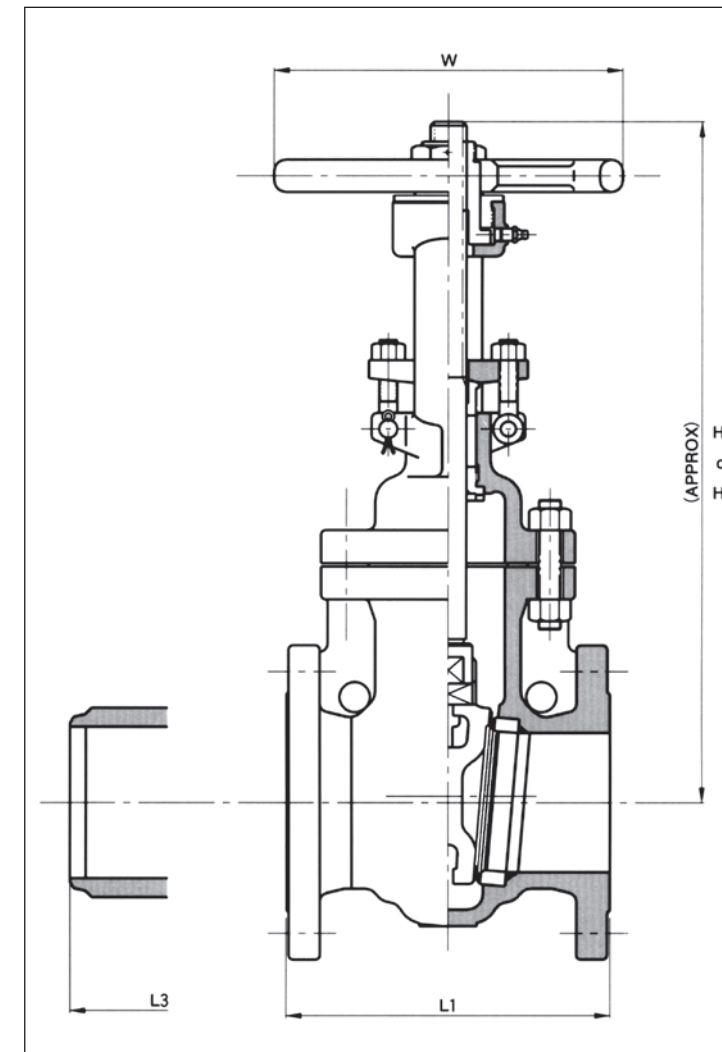

Note: (1) Disc of valves 2½ inch and under are solid wedge. 3 inch and over are flexible wedge.  
 (2) Valves 12 inch and over have thrust bearing.  
 (3) Operation of valves 18 inch and over have bevel gear unit.

WEIGHT AND DIMENSIONS

Valve Size		2"	2½"	3"	4"	6"	8"	10"	12"	14"	16"	18"	20"	24"	26"	28"	30"	32"	34"	36"	38"	40"	42"	48"	
End to End (mm)	R.F.	L1	178	190	203	229	267	292	330	356	384	406	432	457	508	559	610	610	660	711	711	736	762	787	864
	B.W.	L3	216	241	283	305	403	418	457	502	572	610	660	711	813	864	914	914	965	1016	1016	1041	1041	1118	1168
Center to Top (mm)	Open	Ho	383	418	472	576	801	1012	1232	1427	1550	1734	1928	2167	2533	2818	3078	3202	3465	3480	4052	4120	4340	4583	5200
	Close	Hc	324	346	387	464	635	701	960	1103	1192	1330	1928	2167	2533	2818	3078	3202	3465	3480	4052	4120	4340	4583	5200
Diam. of Handwheel (mm)	W		200	200	250	250	300	355	400	520	550	600	460	460	610										
Weight Approx. (kg)	R.F.		18	24	32	50	84	130	198	280	370	496	655	836	1186										
	B.W.		16	20	39	44	79	110	187	270	335	480	625	760	1000										