

CAST STEEL GLOBE VALVES

ASME CLASS 600

SIZE 2" to 16"
Flanged and Butt weld Ends
Bolted Bonnet, O.S. & Y.
R.F. End Type. Fig. No. C1640
R.J. End Type. Fig. No. C1670
B.W. End Type. Fig. No. C1630

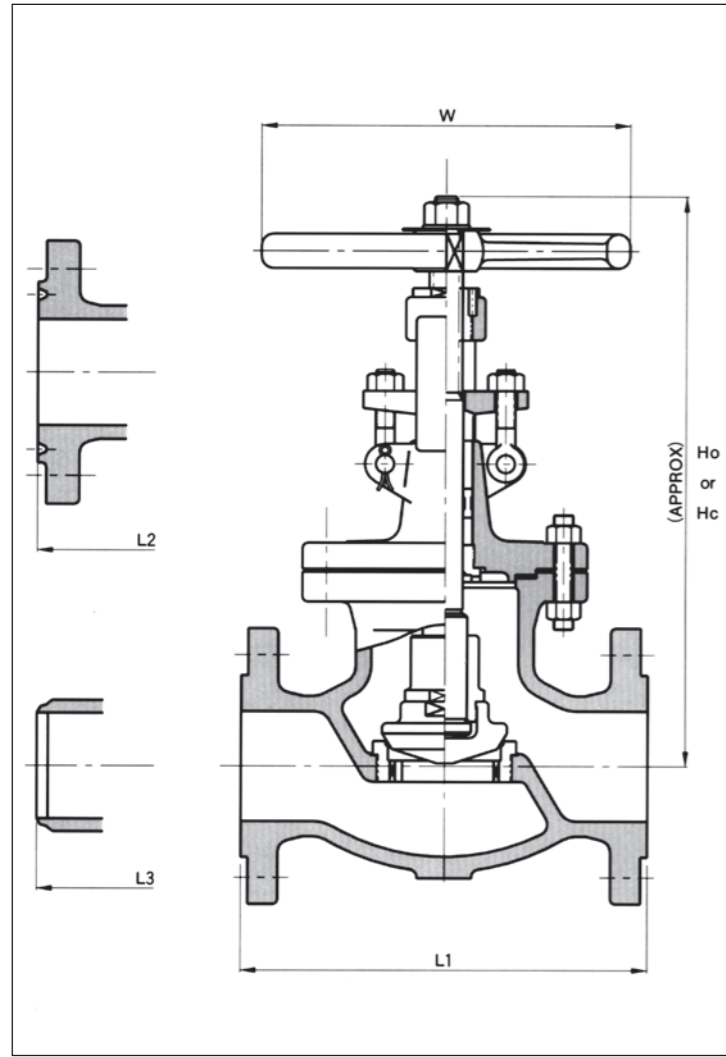

PRESSURE TEST: As per API 598

MATERIAL

NAME OF PART	ASTM	JIS
BODY	A216 WCB	SCPH2
BODY SEAT RING	* A105	* SFVC2A
DISC STEM RING	A276 420	SUS420J2
DISC	A276 420	SUS420J2
STEM	A182 F6a	SUS403
BONNET GASKET	SPIRAL WOUND GRAPHOIL	
BONNET	A216 WCB	SCPH2
BONNET BOLT	A193 B7	SNB7
BONNET BOLT NUT	A194 2H	S45C
BONNET BUSH	A276 420	SUS420J2
LANTERN RING	A276 420	SUS420J2
GLAND PACKING	FLEXIBLE GRAPHITE	
GLAND	A276 420	SUS420J2
GLAND FLANGE	A105	SFVC2A
GLAND EYE BOLT	A193 B7	SNB7
GL. EYE BOLT NUT	A194 2H	S45C
YOKE BUSH	A439 D2	FCDA NiCr
HAND WHEEL	A536	FCD450
LOCK NUT	A36	SS400
NAME PLATE	B209M	ALP

* BODY SEAT RING: STELLITE FACE
 * DISC: 8 INCH AND OVER ARE WCB WITH 13Cr FACE

Note: (1) Stem of valves 8 inch and over are non-rotating type

WEIGHT AND DIMENSIONS

Valve Size		2"	2½"	3"	4"	6"	8"	10"	12"	14"	16"	
End to End (mm)	R.F.	L1	292	330	356	432	559	660	787	838	889	991
	R.J.	L2	295	333	359	435	562	664	791	841	892	994
	B.W.	L3	292	330	356	432	559	660	787	838	889	991
Center to Top (mm)	Open	Ho	493	469	630	704	852	1072	1100	1300	1400	1500
	Close	Hc	435	435	589	654	792	997	1000	1300	1400	1500
Diam. of Handwheel (mm)	W	280	280	355	450	560	685	760	610	610	610	
Weight Approx. (kg)	R.F.		45	60	83	150	327	552	910	1150	1600	2160
	R.J.		45.5	65	83	155	327	520	910	1150	1600	2160
	B.W.		36	47	58	114	258	460	720	850	1400	1900

CAST STEEL SWING CHECK VALVES

ASME CLASS 150

SIZE 2" to 30"
Flanged and Butt weld Ends
Bolted Cover Type.
R.F. End Type. Fig. No. C4240
B.W. End Type. Fig. No. C4230

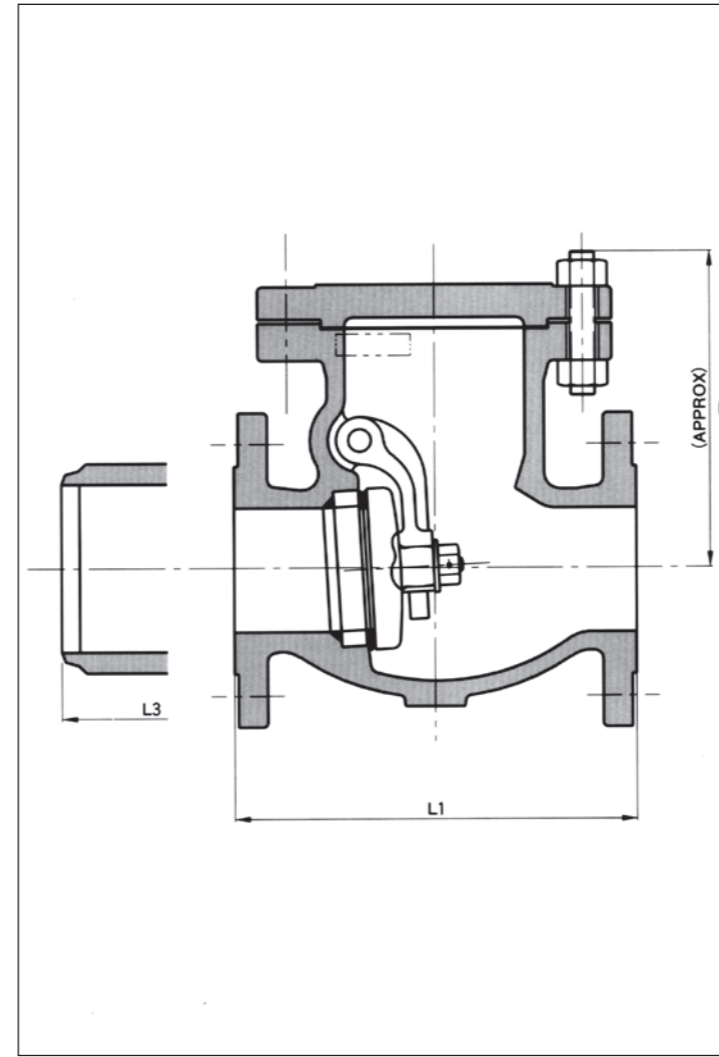

PRESSURE TEST: As per API 598

MATERIAL

NAME OF PART	ASTM	JIS	
BODY	A216 WCB	SCPH2	
BODY SEAT RING	* A105	* SFVC2A	
DISC	4" & UNDER	* A105	* SFVC2A
	6" & OVER	* A216 WCB	* SCPH2
HINGE	A216 WCB	SCPH2	
HINGE PIN	A276 410/420	SUS403	
COVER	A216 WCB	SCPH2	
COVER BOLT	A193 B7	SNB7	
COVER BOLT NUT	A194 2H	S45C	
COVER GASKET	SPIRAL WOUND GRAPHOIL		
KNOCK PIN	A276 304	SUS304	
DISC NUT	A276 410/420	SUS403	
DISC WASHER	A276 410/420	SUS403	
PLUG	A276 410/420	SUS403	
NAME PLATE	B209M	ALP	
PLUG GASKET	A576	MILD STEEL	

* BODY SEAT RING: STELLITE FACE
 * DISC: 13Cr FACE

Note: (1) Valves 6 inch and over are equipped with eye-bolts.(Mild Steel)

WEIGHT AND DIMENSIONS

Valve Size		2"	2½"	3"	4"	6"	8"	10"	12"	14"	16"	18"	20"	24"	26"	28"	30"	
End to End (mm)	R.F.	L1	203	216	241	292	356	495	622	698	787	864	978	978	1295	1295	1448	1524
	B.W.	L3	203	216	241	292	356	495	622	698	787	864	978	978	1295	1295	1448	1524
Center to Top (mm)	H		163	180	190	220	300	335	389	435	511	540	599	614	817	870	950	1000
Weight Approx. (kg)	R.F.		20	26	35	55	87	150	270	380	475	575	770	820	1383			
	B.W.		16	23	30	47	74	119	195	270	400	467	655	800	1280			